

The GPS Orion is an evaluation kit to demonstrate the capability of the Mitel Semiconductor GP2000 Global Positioning chip set. It is a fully functional GPS receiver design which provides full 12 channel parallel tracking hardware and software for GPS system integrators and designers of GPS receiver subsystems. This new approach offers a complete GPS receiver 'engine' design with the design information being freely available, providing the ability to integrate GPS with dedicated IC components. This allows wider design flexibility and lower cost solutions than using third-party module-based receivers. It enables the GP2000 chipset to be evaluated in real applications.

### FEATURES

- Small board size - 95 mm x 50 mm
- 12 channel GPS Receiver architecture
- Highly integrated miniature silicon Front-end IC
- Low cost 12 Channel Correlator IC
- 32 bit RISC processor with spare processing
- Easy to embed into host systems
- Non-volatile data retention
- Supported by Development System (GPS Architect) with access to GPS software source code at minimal cost

The GPS Orion comprises two boards : a GPS Receiver board, and an Interface board. The Receiver board is based on the GP2000 chip set plus complementary components which make a complete GPS Receiver. The Interface board provides power and data conditioning interfaces to peripheral equipment, and long term memory backup.

### GPS Receiver Board

The GPS Orion receiver architecture uses integrated circuits manufactured by Mitel Semiconductor. The GP2000 chipset comprises the GP2015 RF downconverter, the DW9255 35.42MHz (2MHz BW) IF SAW filter, the GP2021 correlator IC, and the 32-bit ARM60 RISC processor.

The use of a GP2015 RF downconverter offers good immunity from out-of-band noise, especially when used with the DW9255 surface mount SAW filter as a 2nd IF filter. The design offers superior RF performance with a high degree of noise rejection from digital sources. The 2-bit sampled IF, in conjunction with triple-conversion architecture provides best-in-class RF jamming resistance.

The GP2021 12 channel correlator can be used to track C/A code for the Standard Positioning Service. Any channels not used can be deselected to save power. The digital interface is compatible with most 16 or 32-bit processors and the IC includes interface logic to allow it to be easily coupled to the ARM60 32 bit RISC processor.

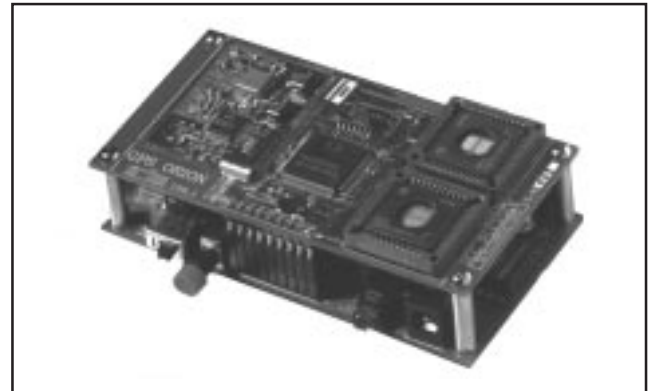

*Fig.1 GPS Orion Receiver Board with Interface Board*

The ARM60-B 32-bit RISC microprocessor offers high instruction throughput and fast real-time interrupt response. The ARM60 offers superior performance for 12 channel processing, which is important for applications such as vehicle tracking and automotive applications.

### Interface Board

The Interface board provides those functions which would normally be included elsewhere in a GPS system. These functions include : voltage regulation, battery back-up (1000 hours memory retention), and serial interfaces to output the information and to input commands and DGPS correction data.

### Software

The software for GPS Orion is stored in EPROM and is self-booting. The software provides many facilities including:

- NMEA 0183, or proprietary WINMON data interfaces
- Navigation position filtering
- Satellite Almanac and Ephemeris save and upload
- Reliable satellite tracking
- RTCM SC-104 Differential Correction input

### Data Retention

The Receiver board includes a supercap (0.22 F) which gives approximately 4 hours retention of volatile data (position, satellite ephemerides, etc.) in isolation from the Interface board. The Interface board includes a rechargeable battery giving approximately 1,000 hours data retention.

# GPS Orion PRODUCT BRIEF

## RELATED PRODUCTS

Part No	Description	Data Sheet Reference
DW9255	35.42 MHz SAW Filter	DS3861
GP2010	GPS RF Front End	DS4056
GP2015	GPS RF Front End in TQFP package	DS4374
GP2021	12 Channel Correlator	DS4077
ARM60	32 Bit RISC Processor	DS4004
GPS Architect	12 Channel GPS Development System	DS4605

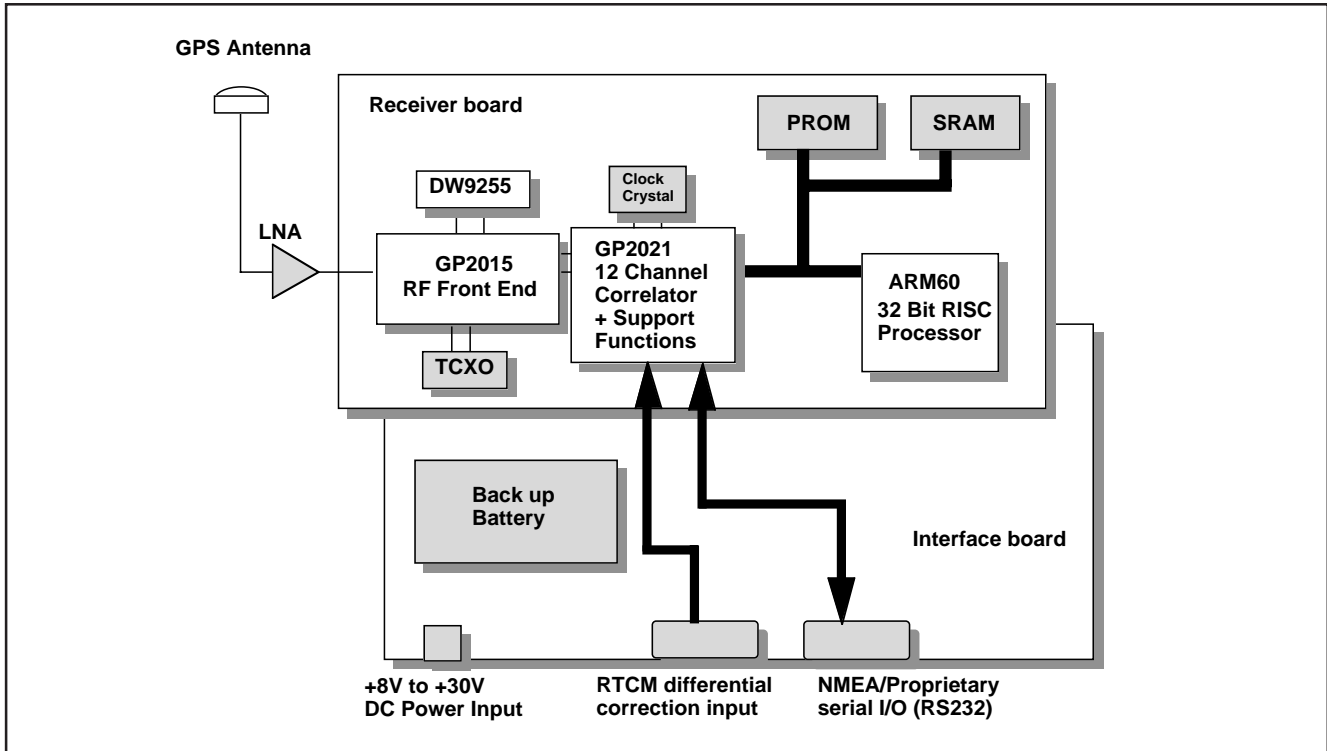

Fig.2 GPS Orion Architecture

## OUTLINE SPECIFICATION

### RECEIVER CHARACTERISTICS

GENERAL:	L1 frequency (1575.42MHz), C/A code direct-sequence spread-spectrum, 12 parallel channel continuous-tracking receiver, using 2-bit digital quantization.	
DATUM:	WGS-84 only	
POSITION ACCURACY: (standard)	25 metres Spherical Error Probability (SEP); 100 metres (2D Root Mean Square) with S/A active.	
POSITION ACCURACY: (DGPS)	3 metres SEP, with S/A active.	
TIME-TO-FIRST-FIX (TTFF - Ref Notes)	<b>Typical</b>	<b>90%</b>
● Cold start:	105 seconds	<165 seconds
● Warm start:		<60 seconds
● Hot start:	11 seconds	<15 seconds
RE-ACQUISITION AFTER SIGNAL LOSS:	< 2 seconds (90%)	
ANTI-JAMMING RESISTANCE:	-20dBm CW to within $\pm 7.5$ MHz of L1 (for <3dB degradation in GPS SNR).	

**DATA I/O**

WINMON MODE: (J2 socket)	Proprietary GEC-Plessey Semiconductors ASCII interface protocol. Full input/output interface, controlling all user-definable options. 19200 baud, 8-bits, No Parity, 1 stop bit.
NMEA MODE: (J2 socket)	NMEA 0183 V2.01 with GGA, RMC, GSV & GSA (output only - not configurable). 4800 baud, 8-bits, No parity, 1 stop bit.  Receiver configuration is still available in NMEA mode, by using WINMON command protocol at 4800 baud, 8-bits, No parity, 1 stop bit.
UPDATE RATE:	1 per second (both modes)
RTCM DIFFERENTIAL CORRECTIONS: (J1 socket)	RTCM SC-104 (input only) - message types 1, 2 & 9-3 9600 baud, 8-bits, No Parity, 1 stop bit

**PHYSICAL CHARACTERISTICS - GPS ORION RECEIVER BOARD**

PRIME POWER: Vdd into receiver board	+5 volts DC, +/- 10%
EXTERNAL BACKUP POWER: Vdr	>+2.2 volts DC, <+5.5volts DC
ACTIVE-ANTENNA POWER:	+5 volts DC available
POWER CONSUMPTION: Vdd	GPS Receiver Board only: 370mA 1.85W With Antenna: 395mA 1.98W
MEMORY/RTC BACKUP POWER CONSUMPTION: Vdr	60µA @ Vdr > +2.2volts DC
INSTALLED SUPERCAP BACKUP LIFE:	4 hours approx.
DATA I/O LEVELS:	CMOS TTL levels (0v & +5v)
SIZE: (GPS Orion Receiver Board only)	95mm x 50mm x 20mm (with RF connector) 95mm x 50mm x 12mm (no RF connector)
SIZE: (with GPS Orion Interface Board attached)	95mm x 50mm x 30mm
CONNECTORS:	RF: SMA socket I/O: 9-pin (1 x 9), 0.1" pitch plug

**PHYSICAL CHARACTERISTICS - GPS ORION INTERFACE BOARD**

INPUT POWER SUPPLY:	+8 volts to +30volts DC
MEMORY / RTC BACKUP BATTERY:	+3.6 v NiCad, 110mAhrs
BATTERY CHARGE - ● RATE: ● TOTAL RECHARGE TIME:	7.5mA typical 18 hours approx.
BATTERY BACKUP LIFE (when supplying Vdr pin on GPS Orion receiver board):	8 weeks approx.
DATA I/O LEVELS:	RS232 levels (±10v)
OUTPUT DATA-MODE CHANGE:	Slide switch
SOFT RESET:	Push button
CONNECTORS:	I/O to Orion: 9-pin (1 x 9), 0.1" pitch socket Power: 2.5mm power socket (centre positive) RS232: 2 x 9 pin D-type plug

**ENVIRONMENTAL CHARACTERISTICS (RECEIVER BOARD ONLY)**

OPERATING TEMP:	-40°C to +85°C
STORAGE TEMP:	-50°C to +110°C

## GPS Orion PRODUCT BRIEF

### NOTES:

1) COLD START:- A cold start results when there is no valid Almanac or Ephemeris information available for the satellite constellation in SRAM, or when the time and/or position information is NOT known (i.e starts at 0 in both cases).

Also a cold start will be initiated if an Almanac is valid, but a fix cannot be achieved within 10 minutes of power-up. This could occur if the receiver position has moved significantly since it was last powered-up, but the position change and time are NOT initialised by the user

2) WARM START:- A warm start results when there is a valid Almanac, and the initial time and position are known in SRAM, but the ephemeris is NOT valid (i.e more than 4 - 6 hours old).

3) HOT START:- A hot start results when there is a valid Almanac, valid ephemeris (i.e. less than 4 - 6 hours old), and when accurate time and position information are also known in SRAM (position error less than 100km, time error less than 5 minutes). This can be simulated by a momentary Soft-Reset (i.e. press the push-button on the GPS Orion interface Board).

### Next step

The GPS Architect is available for designers who wish to develop the software further. This software, which supports the GP2000 chipset is available in both executable and source format, and is available for modification and/or embedding into the target application. Purchase of a GPS Architect Development System provides optimum flexibility and control in the design approach demonstrated by the GPS Orion, and includes a licence to modify the software and use it in embedded form with the target application.



#### HEADQUARTERS OPERATIONS

##### MITEL SEMICONDUCTOR

Cheney Manor, Swindon,  
Wiltshire SN2 2QW, United Kingdom.  
Tel: (01793) 518000  
Fax: (01793) 518411

##### MITEL SEMICONDUCTOR

1500 Green Hills Road,  
Scotts Valley, California 95066-4922  
United States of America.  
Tel (408) 438 2900  
Fax: (408) 438 5576/6231

Internet: <http://www.gpsemi.com>

#### CUSTOMER SERVICE CENTRES

- **FRANCE & BENELUX** Les Ulis Cedex Tel: (1) 69 18 90 00 Fax : (1) 64 46 06 07
- **GERMANY** Munich Tel: (089) 419508-20 Fax : (089) 419508-55
- **ITALY** Milan Tel: (02) 6607151 Fax: (02) 66040993
- **JAPAN** Tokyo Tel: (03) 5276-5501 Fax: (03) 5276-5510
- **KOREA** Seoul Tel: (2) 5668141 Fax: (2) 5697933
- **NORTH AMERICA** Scotts Valley, USA Tel: (408) 438 2900 Fax: (408) 438 5576/6231
- **SOUTH EAST ASIA** Singapore Tel:(65) 3827708 Fax: (65) 3828872
- **SWEDEN** Stockholm Tel: 46 8 702 97 70 Fax: 46 8 640 47 36
- **TAIWAN, ROC** Taipei Tel: 886 2 25461260 Fax: 886 2 27190260
- **UK, EIRE, DENMARK, FINLAND & NORWAY**  
Swindon Tel: (01793) 726666 Fax : (01793) 518582

These are supported by Agents and Distributors in major countries world-wide.

© Mitel Corporation 1998 Publication No. DS4808 Issue No. 1.3 August 1997

TECHNICAL DOCUMENTATION – NOT FOR RESALE. PRINTED IN UNITED KINGDOM

This publication is issued to provide information only which (unless agreed by the Company in writing) may not be used, applied or reproduced for any purpose nor form part of any order or contract nor to be regarded as a representation relating to the products or services concerned. No warranty or guarantee express or implied is made regarding the capability, performance or suitability of any product or service. The Company reserves the right to alter without prior notice the specification, design or price of any product or service. Information concerning possible methods of use is provided as a guide only and does not constitute any guarantee that such methods of use will be satisfactory in a specific piece of equipment. It is the user's responsibility to fully determine the performance and suitability of any equipment using such information and to ensure that any publication or data used is up to date and has not been superseded. These products are not suitable for use in any medical products whose failure to perform may result in significant injury or death to the user. All products and materials are sold and services provided subject to the Company's conditions of sale, which are available on request.

All brand names and product names used in this publication are trademarks, registered trademarks or trade names of their respective owners.